

青岛瑞强机电技术有限公司

钣金连接紧固件及配套设备一站式服务专家

2019

产品样册

盘头环槽铆钉



盘头环槽铆钉种类：

（碳钢）

铆芯	材料	碳钢
	表面处理	环保三价电镀蓝白锌
铆壳	材料	低碳钢
	表面处理	环保三价电镀蓝白锌



（不锈钢）

铆芯	材料	304 系列不锈钢
	表面处理	抛光
铆壳	材料	304 系列低不锈钢
	表面处理	上蜡



（铝合金）

铆芯	材料	铝合金
	表面处理	抛光
铆壳	材料	铝合金
	表面处理	抛光



（盘头大直径环槽）

铆芯	材料	304 系列不锈钢
	表面处理	抛光
铆壳	材料	304 系列低不锈钢
	表面处理	上蜡



该文件仅用于介绍此类产品，并非旨在承诺任何声明，暗示或有法律效益的保证；所有保修权仅包含在我们的书面报价，合同书/采购订单中。建议客户了解每款产品的特性，安装方式，及其正确使用方法。

盘头环槽铆钉

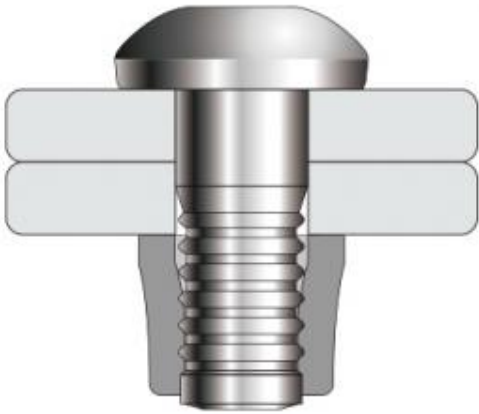

1. 宽铆接范围减少了紧固件库存和简化了库存控制，适应材料厚度的宽度变化范围。
2. 对于高强度组装的高抗剪拉强度。
3. 高强度受控铆接提供了卓越的抗震性。
4. 快速安装，针对大范围的应用。
5. 盘头、沉头、大盘头的铆钉头类型适合多种应用。便于检查撞击。
6. 便于检查撞击。
7. 对于专用安装工具的大范围选择。

铆接过程:

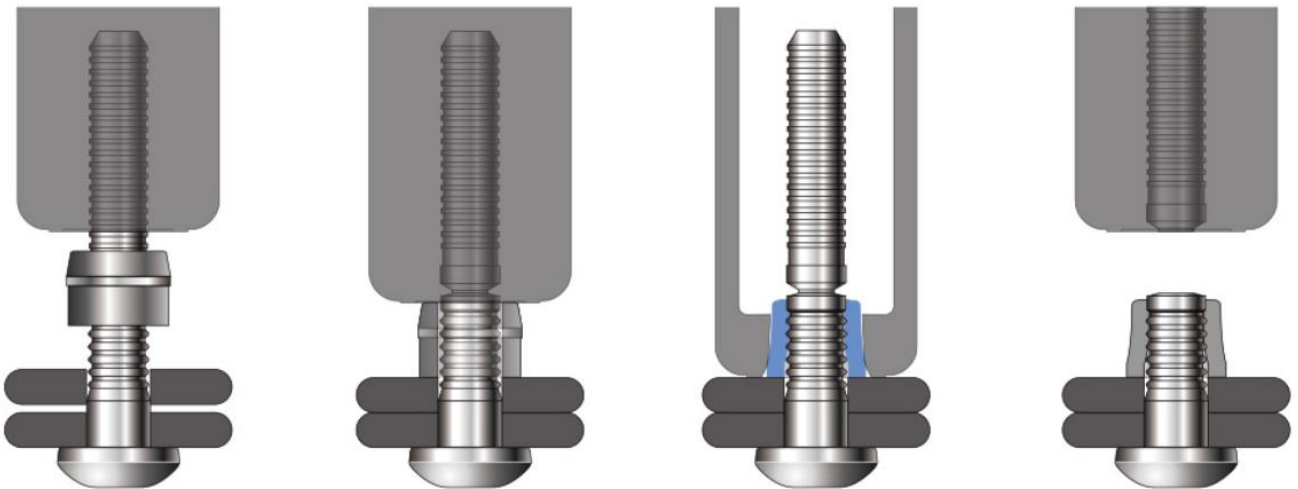

该文件仅用于介绍此类产品，并非旨在承诺任何声明，暗示或有法律效益的保证；所有保修权仅包含在我们的书面报价，合同书/采购订单中。建议客户了解每款产品的特性，安装方式，及其正确使用方法。

铆接过程:

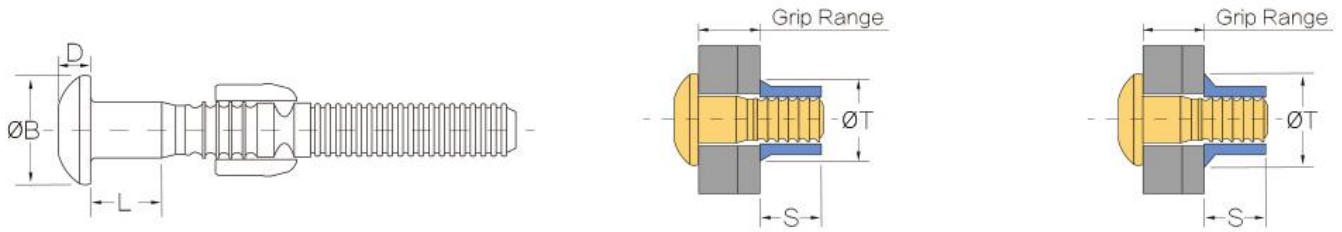

盘头环槽铆钉(碳钢)

Diameter mm	Grip Range		Drill Diameter Nom	L Nom	B Max	D Max	S Max	T Max	S Max	T Max	Shear Force (kN Nom)	Tensile Force (kN Nom)	Product model No.
	Min	Max											
直径	最小范围	最大范围	开孔直径				标准套环		大法兰套环		抗剪力	抗拉力	产品型号
4.8 mm (3/16")	1.57	4.75	5.10	1.57	10.10	3.40	WS-62600 9.40 8.00	WS-15600 10.20 9.90	8.63	7.34	WS-LOCKBOLT-21602		
	3.18	6.35		3.18							WS-LOCKBOLT-21603		
	4.75	7.92		4.75							WS-LOCKBOLT-21604		
	6.35	9.53		6.35							WS-LOCKBOLT-21605		
	7.92	11.10		7.92							WS-LOCKBOLT-21606		
	9.53	12.70		9.53							WS-LOCKBOLT-21607		
	11.10	14.27		11.10							WS-LOCKBOLT-21608		
	12.70	15.88		12.70							WS-LOCKBOLT-21609		
	14.27	17.45		14.27							WS-LOCKBOLT-21610		
	15.88	19.05		15.88							WS-LOCKBOLT-21611		
	17.45	20.62		17.45							WS-LOCKBOLT-21612		
	19.05	22.23		19.05							WS-LOCKBOLT-21613		
	20.62	23.80		20.62							WS-LOCKBOLT-21614		
	22.23	25.40		22.23							WS-LOCKBOLT-21615		
	23.80	26.97		23.80							WS-LOCKBOLT-21616		
6.4 mm (1/4")	1.57	4.75	6.60	1.57	13.40	4.10	WS-62800 12.20 10.60	WS-15800 13.20 13.10	14.73	13.35	WS-LOCKBOLT-21802		
	3.18	6.35		3.18							WS-LOCKBOLT-21803		
	4.75	7.92		4.75							WS-LOCKBOLT-21804		
	6.35	9.53		6.35							WS-LOCKBOLT-21805		
	7.92	11.10		7.92							WS-LOCKBOLT-21806		
	9.53	12.70		9.53							WS-LOCKBOLT-21807		

该文件仅用于介绍此类产品，并非旨在承诺任何声明，暗示或有法律效益的保证；所有保修权仅包含在我们的书面报价，合同书/采购订单中。建议客户了解每款产品的特性，安装方式，及其正确使用方法。

	11.10	14.27		11.10							WS-LOCKBOLT-21808
	12.70	15.88		12.70							WS-LOCKBOLT-21809
	14.27	17.45		14.27							WS-LOCKBOLT-21810
	15.88	19.05		15.88							WS-LOCKBOLT-21811
	17.45	20.62		17.45							WS-LOCKBOLT-21812
	19.05	22.23	6.60	19.05	13.40	4.10	WS-62800 12.20 10.60	WS-15800 13.20 13.10	14.73	13.35	WS-LOCKBOLT-21813
	20.62	23.80		20.62							WS-LOCKBOLT-21814
	22.23	25.40		22.23							WS-LOCKBOLT-21815
	23.80	26.97		23.80							WS-LOCKBOLT-21816
	26.97	30.15		26.97							WS-LOCKBOLT-21818
	30.15	33.32		30.15							WS-LOCKBOLT-21820
	3.18	9.53		3.18							WS-LOCKBOLT-211004
	6.35	12.70		6.35							WS-LOCKBOLT-211006
	9.53	15.88		9.53							WS-LOCKBOLT-211008
	12.70	19.05		12.70							WS-LOCKBOLT-211010
	15.88	22.23		15.88							WS-LOCKBOLT-211012
	19.05	25.40		19.05							WS-LOCKBOLT-211014
	22.23	28.58		22.23							WS-LOCKBOLT-211016
8.0 mm (5/16")	25.40	31.75	8.20	25.40	16.70	5.50	WS-621000 15.50 13.30	WS-151000 16.80 16.30	22.38	21.81	WS-LOCKBOLT-211018
	28.58	34.93		28.58							WS-LOCKBOLT-211020
	31.75	38.10		31.75							WS-LOCKBOLT-211022
	34.93	41.28		34.93							WS-LOCKBOLT-211024
	38.10	44.45		38.10							WS-LOCKBOLT-211026
	41.28	47.63		41.28							WS-LOCKBOLT-211028
	44.45	50.80		44.45							WS-LOCKBOLT-211030
	47.63	53.98		47.63							WS-LOCKBOLT-211032

该文件仅用于介绍此类产品，并非旨在承诺任何声明，暗示或有法律效益的保证；所有保修权仅包含在我们的书面报价，合同书/采购订单中。建议客户了解每款产品的特性，安装方式，及其正确使用方法。

	3.18	9.53		3.18								WS-LOOKBOLT-211204
	6.35	12.70		6.35								WS-LOOKBOLT-211206
	9.53	15.88		9.53								WS-LOOKBOLT-211208
	12.70	19.05		12.70								WS-LOOKBOLT-211210
	15.88	22.23		15.88								WS-LOOKBOLT-211212
	19.05	25.40		19.05								WS-LOOKBOLT-211214
	22.23	28.58		22.23								WS-LOOKBOLT-211216
9.6mm (3/8")	25.40	31.75	9.80	25.40	20.10	6.70	WS-621200 18.60 15.50	WS-151200 20.00 20.00	32.08	28.93		WS-LOOKBOLT-211218
	28.58	34.93		28.58								WS-LOOKBOLT-211220
	31.75	38.10		31.75								WS-LOOKBOLT-211222
	34.93	41.28		34.93								WS-LOOKBOLT-211224
	38.10	44.45		38.10								WS-LOOKBOLT-211226
	41.28	47.63		41.28								WS-LOOKBOLT-211228
	44.45	50.80		44.45								WS-LOOKBOLT-211230
	47.63	53.98		47.63								WS-LOOKBOLT-211232

该文件仅用于介绍此类产品，并非旨在承诺任何声明，暗示或有法律效益的保证；所有保修权仅包含在我们的书面报价，合同书/采购订单中。建议客户了解每款产品的特性，安装方式，及其正确使用方法。

盘头环槽铆钉（不锈钢）







 Diameter mm	 Grip Range		 Drill Diameter Nom	L	B	D	S	T	S	T	 Shear Force (KN Nom)	 Tensile Force (KN Nom)	 Product model No.
	Min	Max		Nom	Max	Max	Max	Max	Max	Max			
直径	最小范围	最大范围	开孔直径				标准套环		大法兰套环		抗剪力	抗拉力	产品型号
4.8 mm (3/16")	1.57	4.75	5.10	1.57	10.00	3.40	WS-05600 9.40 8.00	WS-48600 10.20 9.90	7.79	9.26	WS-LOCKBOLT-91602		
	3.18	6.35		3.18							WS-LOCKBOLT-91603		
	4.75	7.92		4.75							WS-LOCKBOLT-91604		
	6.35	9.53		6.35							WS-LOCKBOLT-91605		
	7.92	11.10		7.92							WS-LOCKBOLT-91606		
	9.53	12.70		9.53							WS-LOCKBOLT-91607		
	11.10	14.27		11.10							WS-LOCKBOLT-91608		
	12.70	15.88		12.70							WS-LOCKBOLT-91609		
	14.27	17.45		14.27							WS-LOCKBOLT-91610		
	15.88	19.05		15.88							WS-LOCKBOLT-91611		
	17.45	20.62		17.45							WS-LOCKBOLT-91612		
	19.05	22.23		19.05							WS-LOCKBOLT-91613		
	20.62	23.80		20.62							WS-LOCKBOLT-91614		
	22.23	25.40		22.23							WS-LOCKBOLT-91615		
	23.80	26.97		23.80							WS-LOCKBOLT-91616		
	25.40	28.58		25.40							WS-LOCKBOLT-91617		
26.97	30.15	26.97	WS-LOCKBOLT-91618										
28.58	31.75	28.58	WS-LOCKBOLT-91619										
30.15	33.32	30.15	WS-LOCKBOLT-91620										
6.4 mm (1/4")	1.57	4.75	6.60	1.57	13.40	4.10	WS-05800 12.20 10.60	WS-48800 13.20 13.10	14.55	17.71	WS-LOCKBOLT-91802		
	3.18	6.35		3.18							WS-LOCKBOLT-91803		
	4.75	7.92		4.75							WS-LOCKBOLT-91804		
	6.35	9.53		6.35							WS-LOCKBOLT-91805		
	7.92	11.10		7.92							WS-LOCKBOLT-91806		
	9.53	12.70		9.53							WS-LOCKBOLT-91807		
	11.10	14.27	6.60	11.10	13.40	4.10	WS-05800 12.20 10.60	WS-48800 13.20 13.10	14.55	17.71	WS-LOCKBOLT-91808		
	12.70	15.88		12.70							WS-LOCKBOLT-91809		
	14.27	17.45		14.27							WS-LOCKBOLT-91810		
	15.88	19.05		15.88							WS-LOCKBOLT-91811		
	17.45	20.62		17.45							WS-LOCKBOLT-91812		
	19.05	22.23		19.05							WS-LOCKBOLT-91813		
	20.62	23.80		20.62							WS-LOCKBOLT-91814		
	22.23	25.40		22.23							WS-LOCKBOLT-91815		
	23.80	26.97		23.80							WS-LOCKBOLT-91816		
	26.97	30.15		26.97							WS-LOCKBOLT-91818		
30.15	33.32	30.15	WS-LOCKBOLT-91820										

该文件仅用于介绍此类产品，并非旨在承诺任何声明，暗示或有法律效益的保证；所有保修权仅包含在我们的书面报价，合同书/采购订单中。建议客户了解每款产品的特性，安装方式，及其正确使用方法。

盘头环槽铆钉（不锈钢）







8.0 mm (5/16")	25.40	31.75	8.20	25.40	16.70	5.50	WS-051000 15.50 13.30	NA	22.24	29.80	WS-LOCKBOLT-911018
	28.58	34.93		28.58							WS-LOCKBOLT-911020
	31.75	38.10		31.75							WS-LOCKBOLT-911022
	34.93	41.28		34.93							WS-LOCKBOLT-911024
	38.10	44.45		38.10							WS-LOCKBOLT-911026
	41.28	47.63		41.28							WS-LOCKBOLT-911028
	44.45	50.80		44.45							WS-LOCKBOLT-911030
	47.63	53.98		47.63							WS-LOCKBOLT-911032
9.6mm (3/8")	3.18	9.53	9.80	3.18	20.00	6.70	WS-051200 18.60 15.50	NA	31.58	37.81	WS-LOCKBOLT-911204
	6.35	12.70		6.35							WS-LOCKBOLT-911206
	9.53	15.88		9.53							WS-LOCKBOLT-911208
	12.70	19.05		12.70							WS-LOCKBOLT-911210
	15.88	22.23		15.88							WS-LOCKBOLT-911212
	19.05	25.40		19.05							WS-LOCKBOLT-911214
	22.23	28.58		22.23							WS-LOCKBOLT-911216
	25.40	31.75		25.40							WS-LOCKBOLT-911218
	28.58	34.93		28.58							WS-LOCKBOLT-911220
	31.75	38.10		31.75							WS-LOCKBOLT-911222
	34.93	41.28		34.93							WS-LOCKBOLT-911224
	38.10	44.45		38.10							WS-LOCKBOLT-911226
	41.28	47.63		41.28							WS-LOCKBOLT-911228
	44.45	50.80		44.45							WS-LOCKBOLT-911230
	47.63	53.98		47.63							WS-LOCKBOLT-911232

盘头环槽铆钉（铝合金）

 Diameter mm	 Grip Range		 Drill Diameter Nom	L	B	D	S	T	S	T	 Shear Force (kN Nom)	 Tensile Force (kN Nom)	 Product model No.
	Min	Max		Nom	Max	Max	Max	Max	Max	Max			
直径	最小范围	最大范围	开孔直径				标准套环		大法兰套环		抗剪断力	抗拉断力	产品型号
4.8 mm (3/16")	3.18	6.35	5.10	3.18	8.90	2.20	WS-37600 9.40 8.00		WS-39600 10.20 9.90	4.67	4.72	WS-LOCKBOLT-02603	
	4.75	7.92		4.75								WS-LOCKBOLT-02604	
	6.35	9.53		6.35								WS-LOCKBOLT-02605	
	7.92	11.10		7.92								WS-LOCKBOLT-02606	
	9.53	12.70		9.53								WS-LOCKBOLT-02607	
	11.10	14.27		11.10								WS-LOCKBOLT-02608	
	12.70	15.88		12.70								WS-LOCKBOLT-02609	
	14.27	17.45		14.27								WS-LOCKBOLT-02610	
	15.88	19.05		15.88								WS-LOCKBOLT-02611	
	17.45	20.62		17.45								WS-LOCKBOLT-02612	
	19.05	22.23		19.05								WS-LOCKBOLT-02613	
	20.62	23.80		20.62								WS-LOCKBOLT-02614	
	22.23	25.40		22.23								WS-LOCKBOLT-02615	
	23.80	26.97		23.80								WS-LOCKBOLT-02616	
	25.40	28.58		25.40								WS-LOCKBOLT-02617	
	26.97	30.15		26.97								WS-LOCKBOLT-02618	
28.58	31.75	28.58	WS-LOCKBOLT-02619										
30.15	33.32	30.15	WS-LOCKBOLT-02620										
6.4 mm (1/4")	3.18	6.35	6.60	3.18	11.80	2.90	WS-37800 12.20 10.60		WS-39800 13.20 13.10	8.34	7.92	WS-LOCKBOLT-02803	
	4.75	7.92		4.75								WS-LOCKBOLT-02804	
	6.35	9.53		6.35								WS-LOCKBOLT-02805	
	7.92	11.10		7.92								WS-LOCKBOLT-02806	
	9.53	12.70		9.53								WS-LOCKBOLT-02807	
6.4 mm (1/4")	11.10	14.27	6.60	11.10	11.80	2.90	WS-37800 12.20 10.60		WS-39800 13.20 13.10	8.34	7.92	WS-LOCKBOLT-02808	
	12.70	15.88		12.70								WS-LOCKBOLT-02809	
	14.27	17.45		14.27								WS-LOCKBOLT-02810	
	15.88	19.05		15.88								WS-LOCKBOLT-02811	
	17.45	20.62		17.45								WS-LOCKBOLT-02812	
	19.05	22.23		19.05								WS-LOCKBOLT-02813	
	20.62	23.80		20.62								WS-LOCKBOLT-02814	
	22.23	25.40		22.23								WS-LOCKBOLT-02815	
	23.80	26.97		23.80								WS-LOCKBOLT-02816	
	26.97	30.15		26.97								WS-LOCKBOLT-02818	
30.15	33.32	30.15	WS-LOCKBOLT-02820										
4.8 mm (3/16")	3.18	9.53	5.10	3.18	8.90	2.20	WS-37600 9.40 8.00		WS-39600 10.20 9.90	4.67	4.72	WS-LOCKBOLT-021004	
	6.35	12.70		6.35								WS-LOCKBOLT-021006	
	9.53	15.88		9.53								WS-LOCKBOLT-021008	
	12.70	19.05		12.70								WS-LOCKBOLT-021010	
	15.88	22.23		15.88								WS-LOCKBOLT-021012	
	19.05	25.40		19.05								WS-LOCKBOLT-021014	
	22.23	28.58		22.23								WS-LOCKBOLT-021016	

8.0 mm (5/16")	25.40	31.75	8.20	25.40	14.80	3.70	WS-371000 15.50 13.30	WS-391000 16.80 16.30	13.02	12.68	WS-LOCKBOLT-021018
	28.58	34.93		28.58							WS-LOCKBOLT-021020
	31.75	38.10		31.75							WS-LOCKBOLT-021022
	34.93	41.28		34.93							WS-LOCKBOLT-021024
	38.10	44.45		38.10							WS-LOCKBOLT-021026
	41.28	47.63		41.28							WS-LOCKBOLT-021028
	44.45	50.80		44.45							WS-LOCKBOLT-021030
	47.63	53.98		47.63							WS-LOCKBOLT-021032
9.6mm (3/8")	6.35	12.70	9.80	6.35	17.70	4.40	WS-371200 18.60 15.50	WS-391200 20.00 20.00	18.69	18.68	WS-LOCKBOLT-021206
	9.53	15.88		9.53							WS-LOCKBOLT-021208
	12.70	19.05		12.70							WS-LOCKBOLT-021210
	15.88	22.23		15.88							WS-LOCKBOLT-021212
	19.05	25.40		19.05							WS-LOCKBOLT-021214
	22.23	28.58		22.23							WS-LOCKBOLT-021216
	25.40	31.75		25.40							WS-LOCKBOLT-021218
	28.58	34.93		28.58							WS-LOCKBOLT-021220
	31.75	38.10		31.75							WS-LOCKBOLT-021222
	34.93	41.28		34.93							WS-LOCKBOLT-021224
	38.10	44.45		38.10							WS-LOCKBOLT-021226
	41.28	47.63		41.28							WS-LOCKBOLT-021228
	44.45	50.80		44.45							WS-LOCKBOLT-021230
	47.63	53.98		47.63							WS-LOCKBOLT-021232

盘头大直径环槽铆钉

 Diameter mm	 Grip Range		 Drill Diameter		L	B	D	S	T	S	T	 Shear Force (kN Nom)	 Tensile Force (kN Nom)	 Product model No.
	mm	Min	Max	Nom	Nom	Max	Max	Max	Max	Max	Max	(kN Nom)	(kN Nom)	No.
直径	最小范围	最大范围	开孔直径					标准套环		大法兰套环		抗剪断力	抗拉断力	产品型号
12.7mm (1/2")	6.00	13.00	13.20	14.30	32.00	23.00	9.20	WS-621600 15.90	WS-151600 19.20 26.20	64.00	75.80	WS-LOCKBOLT-611604		
	12.00	19.00			38.00							WS-LOCKBOLT-611608		
	18.00	25.00			44.00							WS-LOCKBOLT-611612		
	24.00	31.00			50.00							WS-LOCKBOLT-611616		
	31.00	38.00			57.00							WS-LOCKBOLT-611620		
	37.00	44.00			63.00							WS-LOCKBOLT-611624		
	44.00	51.00			70.00							WS-LOCKBOLT-611628		
	50.00	57.00			76.00							WS-LOCKBOLT-611632		
	57.00	64.00			83.00							WS-LOCKBOLT-611636		
	63.00	70.00			89.00							WS-LOCKBOLT-611640		
	70.00	77.00			96.00							WS-LOCKBOLT-611644		
	77.00	84.00			103.00							WS-LOCKBOLT-611648		
	83.00	90.00			109.00							WS-LOCKBOLT-611652		
	89.00	96.00			115.00							WS-LOCKBOLT-611656		
	95.00	102.00			121.00							WS-LOCKBOLT-611660		
	15.9mm (5/8")	6.00			13.00							16.40	17.50	36.00
12.00		19.00	42.00	WS-LOCKBOLT-612008										
18.00		25.00	48.00	WS-LOCKBOLT-612012										
24.00		31.00	54.00	WS-LOCKBOLT-612016										
31.00		38.00	61.00	WS-LOCKBOLT-612020										
37.00		44.00	67.00	WS-LOCKBOLT-612024										
44.00		51.00	74.00	WS-LOCKBOLT-612028										
50.00		57.00	80.00	WS-LOCKBOLT-612032										
57.00		64.00	87.00	WS-LOCKBOLT-612036										
63.00		70.00	93.00	WS-LOCKBOLT-612040										
70.00		77.00	100.00	WS-LOCKBOLT-612044										
77.00		84.00	107.00	WS-LOCKBOLT-612048										
15.9mm (5/8")	83.00	90.00	16.40	17.50	36.00	30.00	11.30	WS-622000 21.90	WS-152000 24.30 32.30	100.00	120.50	WS-LOCKBOLT-612052		
	89.00	96.00			42.00							WS-LOCKBOLT-612056		
	95.00	102.00			48.00							WS-LOCKBOLT-612060		
19.1mm (3/4")	6.00	13.00	19.60	20.70	39.00	35.00	13.50	WS-622400 24.30	WS-152400 29.00 38.70	144.10	178.40	WS-LOCKBOLT-612404		
	12.00	19.00			45.00							WS-LOCKBOLT-612408		
	18.00	25.00			51.00							WS-LOCKBOLT-612412		
	24.00	31.00			57.00							WS-LOCKBOLT-612416		
	31.00	38.00			64.00							WS-LOCKBOLT-612420		
	37.00	44.00			70.00							WS-LOCKBOLT-612424		
	44.00	51.00			77.00							WS-LOCKBOLT-612428		
	50.00	57.00			83.00							WS-LOCKBOLT-612432		
	57.00	64.00			90.00							WS-LOCKBOLT-612436		
	63.00	70.00			96.00							WS-LOCKBOLT-612440		
	70.00	77.00			103.00							WS-LOCKBOLT-612444		
	77.00	84.00			110.00							WS-LOCKBOLT-612448		
	83.00	90.00			116.00							WS-LOCKBOLT-612452		
	89.00	96.00			122.00							WS-LOCKBOLT-612456		
	95.00	102.00			128.00							WS-LOCKBOLT-612460		

盘头大直径环槽铆钉

25.4mm (1.0")	6.00	13.00	26.00	27.00	46.00	47.00	17.70	WS-623200 32.00	WS-153200 38.00 48.50	251.30	323.40	WS-LOCKBOLT-613204
	12.00	19.00			52.00							WS-LOCKBOLT-613208
	18.00	25.00			58.00							WS-LOCKBOLT-613212
	24.00	31.00			64.00							WS-LOCKBOLT-613216
	31.00	38.00			71.00							WS-LOCKBOLT-613220
	37.00	44.00			77.00							WS-LOCKBOLT-613224
	44.00	51.00			84.00							WS-LOCKBOLT-613228
	50.00	57.00			90.00							WS-LOCKBOLT-613232
	57.00	64.00			97.00							WS-LOCKBOLT-613236
	63.00	70.00			103.00							WS-LOCKBOLT-613240
	70.00	77.00			110.00							WS-LOCKBOLT-613244
	77.00	84.00			117.00							WS-LOCKBOLT-613248
	83.00	90.00			123.00							WS-LOCKBOLT-613252
	89.00	96.00			129.00							WS-LOCKBOLT-613256
	95.00	102.00			135.00							WS-LOCKBOLT-613260

电话: +86 532 6898 2828

传真: +86 532 6898 2818

邮件: chinawacom@163.com

地址: 青岛市高新区宝源路780号联东U谷18栋

青岛瑞强机电技术有限公司

连接您我，紧固世界！

Wacom

www.chinawacom.com